



MA3 Features

- Miniature size (0.48 in. diameter)
- Non-contacting magnetic single chip sensing technology
- -40C to 125C operating temperature range
- 10-bit Analog output - 2.6 kHz sampling rate
- 10-bit PWM output - 1,024 positions per revolution, 1 kHz
- 12-bit PWM output - 4,096 positions per revolution, 250 Hz



MA3 Product Description

The MA3 is a miniature rotary absolute shaft encoder that reports the shaft position over 360° with no stops or gaps. The MA3 is available with an analog or a pulse width modulated (PWM) digital output.



Analog output provides an analog voltage that is proportional to the absolute shaft position. Analog output is only available in 10-bit resolution.

PWM output provides a pulse duty cycle that is proportional to the absolute shaft position. PWM output is available in 10-bit and 12-bit resolutions. While the accuracy is the same for both encoders, the 12-bit version provides a higher resolution.

Three shaft torque versions are available: high torque (-D option), low torque (-N), and ball-bearing (-B). The high and low torque versions have a stainless steel shaft and brass bushing lubricated with grease to provide ideal torque for panel mount, human-interface applications. The ball-bearing version has a brass shaft and miniature precision ball bearings suitable for high speed and ultra-low torque applications. The ball-bearing version is only available with a 1/8 in. shaft diameter.

Connecting to the MA3 is simple. The 3-pin high retention snap-in 1.25mm pitch polarized connector provides for +5V, output, and ground.

Mechanical Drawings

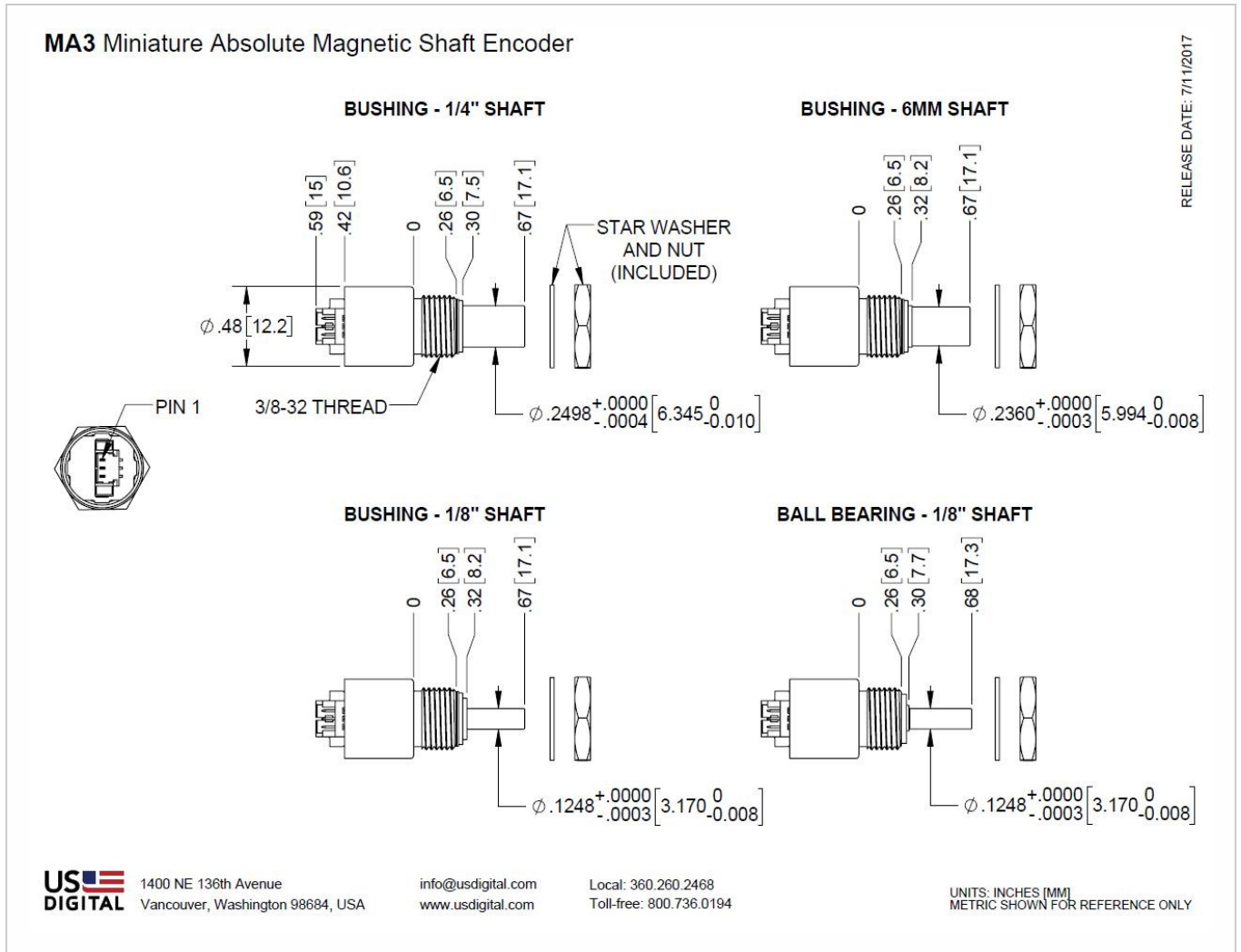

Specifications

ENVIRONMENTAL

PARAMETER	VALUE	UNITS
Operating Temperature	-40 to +125	C
Vibration (5Hz to 2kHz)	20	G
Electrostatic Discharge, Human Body Model MIL-STD-883E, Method 3015.7	± 2	kV



MECHANICAL

SPECIFICATION	SLEEVE BUSHING	BALL BEARING
Moment of Inertia	4.1 x 10 ⁻⁶ oz-in-s ²	4.1 x 10 ⁻⁶ oz-in-s ²
Max. Shaft Speed (1) (mechanical)	100 RPM	15000 RPM
Max. Acceleration	10000 rad/sec ²	250000 rad/sec ²
Max. Shaft Torque	0.5 ± 0.2 in-oz (D - torque option) 0.3 in-oz (N- torque option)	0.05 in-oz
Max. Shaft Loading	2 lb. dynamic 20 lb. static	1 lb.
Bearing Life (2)	> 1,000,000 revolutions	$L_{10} = (18.3/F_r)^3$ Where L_{10} = bearing life in millions of revs, and F_r = radial shaft loading in pounds
Weight	0.46 oz.	0.37 oz.
Max. Shaft Runout	0.0015 in. T.I.R.	0.0015 in. T.I.R.
Technical Bulletin TB1001 - Shaft and Bore Tolerances	Download (https://www.usdigital.com/support/resources/reference/technical-docs/technical-bulletins/shaft-and-bore-tolerances-tb1001/)	

(1) The chip that decodes position uses sampled data. There will be fewer readings per revolution as the speed increases. The formula for number of readings per revolution is given by:

10-bit PWM:

$$n = 625200 / \text{rpm}$$

12-bit PWM / Analog:

$$n = 156600 / \text{rpm}$$

(2) only valid with negligible axial shaft loading

MOUNTING

PARAMETER	VALUE	UNITS
Hole Diameter	0.375 +0.005 / -0.0	in.
Panel Thickness	0.125 max.	in.
Panel Nut Max. Torque	20.0	in-lbs



MATERIALS

COMPONENT	MATERIAL	TORQUE OPTION(S)
Shaft	Stainless	Sleeve Bushing (-D and -N options)
	Brass	Ball Bearing (-B option only)
Bushing	Brass	-

MAGNETIC FIELD CROSSTALK

The MA3 absolute encoder contains a small internal magnet, mounted on the end of the shaft that generates a weak magnetic field extending outside the housing of each encoder. If two MA3 units are to be installed closer than 1 inch apart (measured between the center of both shafts), a magnetic shield, such as a small steel plate should be installed in between to prevent one encoder from causing small changes in the reported position through magnetic field cross-talk.

ELECTRICAL

PARAMETER	MIN.	TYP.	MAX.	UNITS
Power Supply	4.5	5.0	5.5	Volts
Supply Current	-	16	20	mA
Power-up Time	-	-	50	mS

ANALOG OUTPUT OPERATION



V_{CC} = 5V

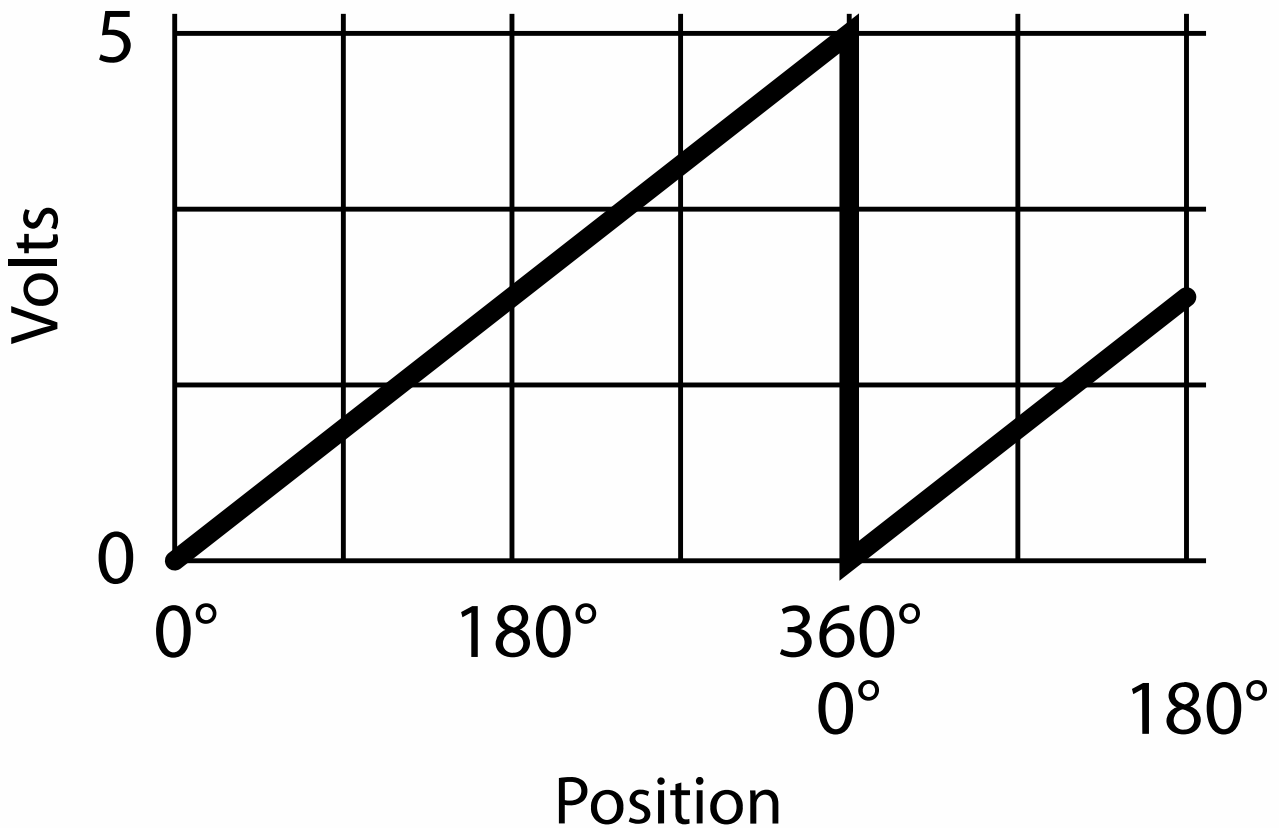

Analog output is only available in 10-bit resolution. The analog output voltage is ratiometric to the power supply voltage and will typically swing within 15 millivolts of the power supply rails with no output load. This non-linearity near the rails increases with increasing output loads. For this reason, the output load impedance should be $\geq 4.7\text{k}\Omega$ and less than 100pF. The graphs below show the typical output levels for various output loads when powered by a 5V supply.

PARAMETER	MIN.	TYP.	MAX.	UNITS
Position Sampling Rate	2.35	2.61	2.87	kHz
Propagation Delay	-	-	384	μS
Analog Output Voltage Maximum (1)	-	4.987	-	Volts
Analog Output Voltage Minimum (1)	-	0.015	-	Volts
Output Short Circuit Sink Current (2)	-	32	50	mA
Output Short Circuit Source Current (2)	-	36	66	mA
Output Noise (2)	160	220	490	μVrms
Output Transition Noise (3)	-	0.03	-	Deg. RMS

(1) With no output load. See graphs below.



- (2) Continuous short to +5V or ground will not damage the MA3.
- (3) Transition noise is the jitter in the transition between two adjacent position steps.

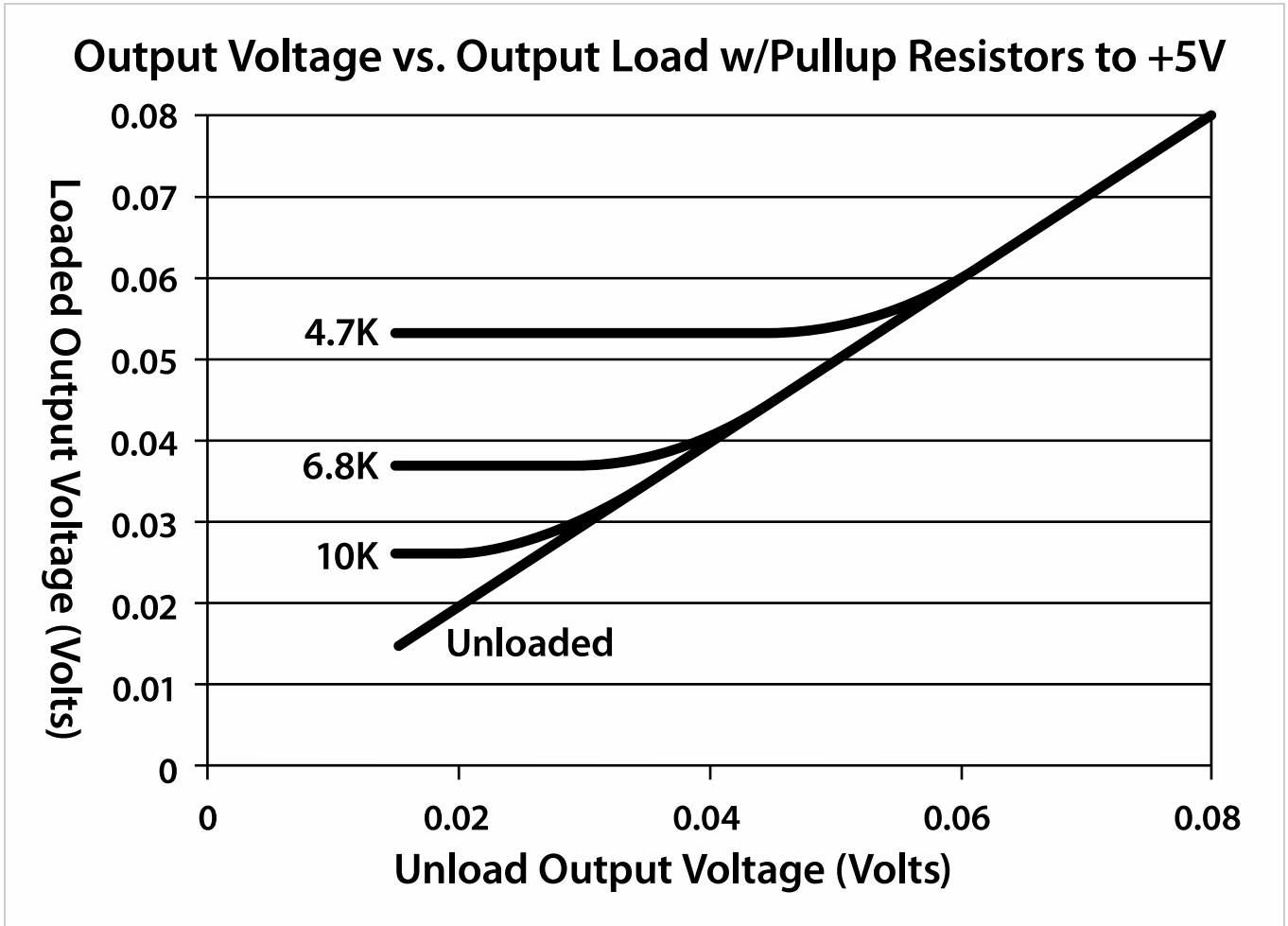



Output Voltage vs. Output Load w/Pulldown Resistors to GND

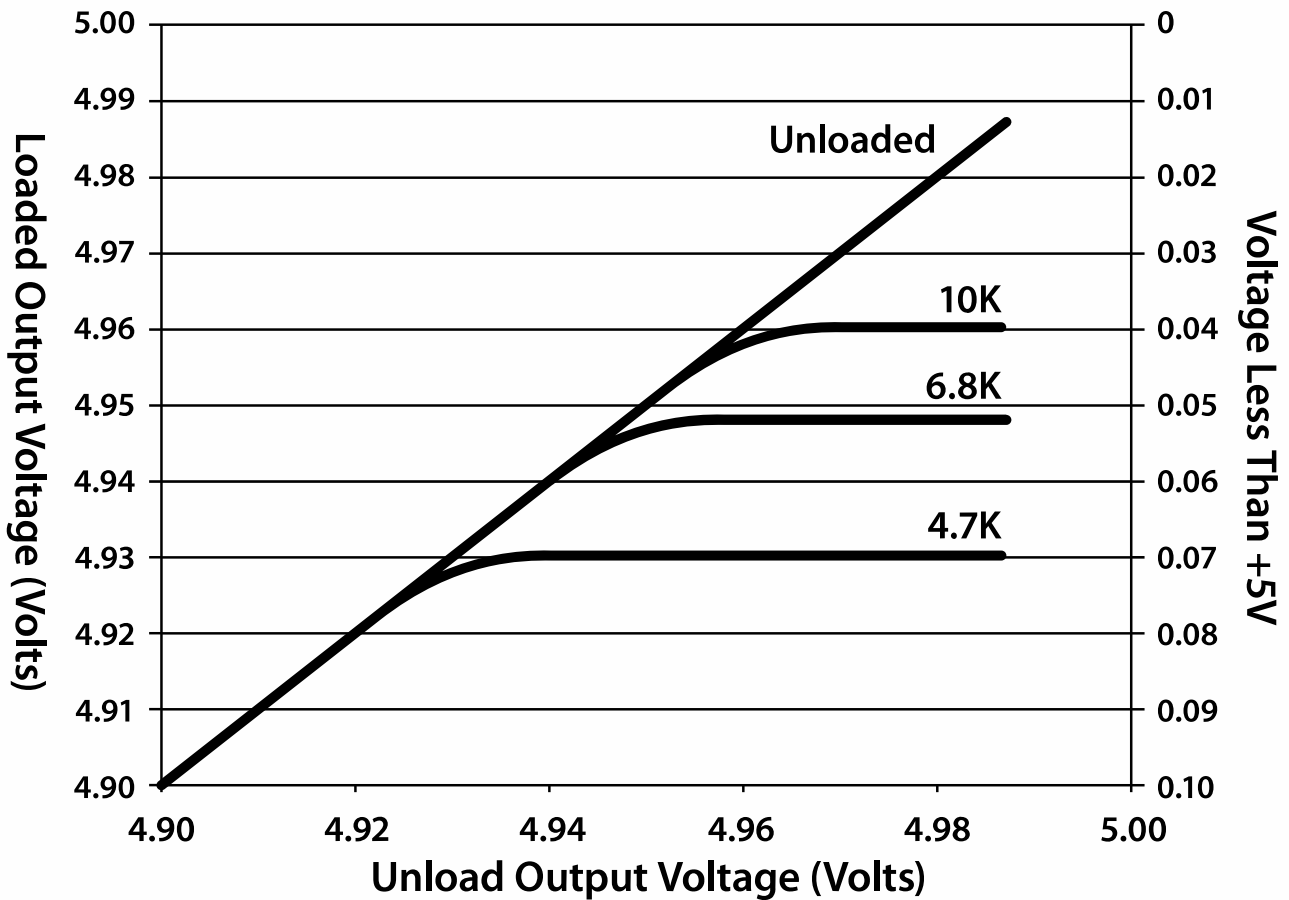

PWM OUTPUT OPERATION

The magnetic sensor chip in the MA3 has an on-chip RC oscillator which is factory trimmed to 5% accuracy at room temperature (10% over full temperature range). This tolerance influences the sampling rate and pulse period of the PWM output. If only the PWM pulse width t_{on} and the nominal pulse period is used to measure the angle, the resulting value also has this timing tolerance. However, this tolerance can be cancelled by measuring both t_{on} and t_{off} and calculating the angle from the duty cycle.



MA3 Miniature Absolute Magnetic Shaft Encoder

PARAMETER	MIN.	TYP.	MAX.	UNITS
PWM Frequency (-40C to 125C)				
10-bit	0.877	0.975	1.072	kHz
12-bit	220	244	268	Hz
Minimum Pulse Width				
10-bit	0.95	1.00	1.05	µS
12-bit	0.95	1.00	1.05	µS
Maximum Pulse Width				
10-bit	974	1025	1076	µS
12-bit	3892	4097	4302	µS
Internal Sampling Rate				
10-bit	9.38	10.42	11.46	kHz
12-bit	2.35	2.61	2.87	kHz
Propagation				
10-bit	-	-	48	µS
12-bit	-	-	384	µS
Output Transition Noise, 12-bit version (1)		0.03		Deg. RMS
Output Transition Noise, 10-bit version (1)		0.12		Deg. RMS
Output High Voltage (V _{OH} : @4mA Source) (2)	V _{CC} -0.5	-	-	V
Output Low Voltage (V _{OL} : @4mA Sink) (2)	-	-	0.4	V

(1) Transition noise is the jitter in the transition between two adjacent position steps.

(2) Continuous short to +5V or ground will not damage the MA3.

10-bit PWM:

$$x = ((t_{on} * 1026) / (t_{on} + t_{off})) - 1$$

If $x \leq 1022$, then Position = x

If $x = 1024$, then Position = 1023

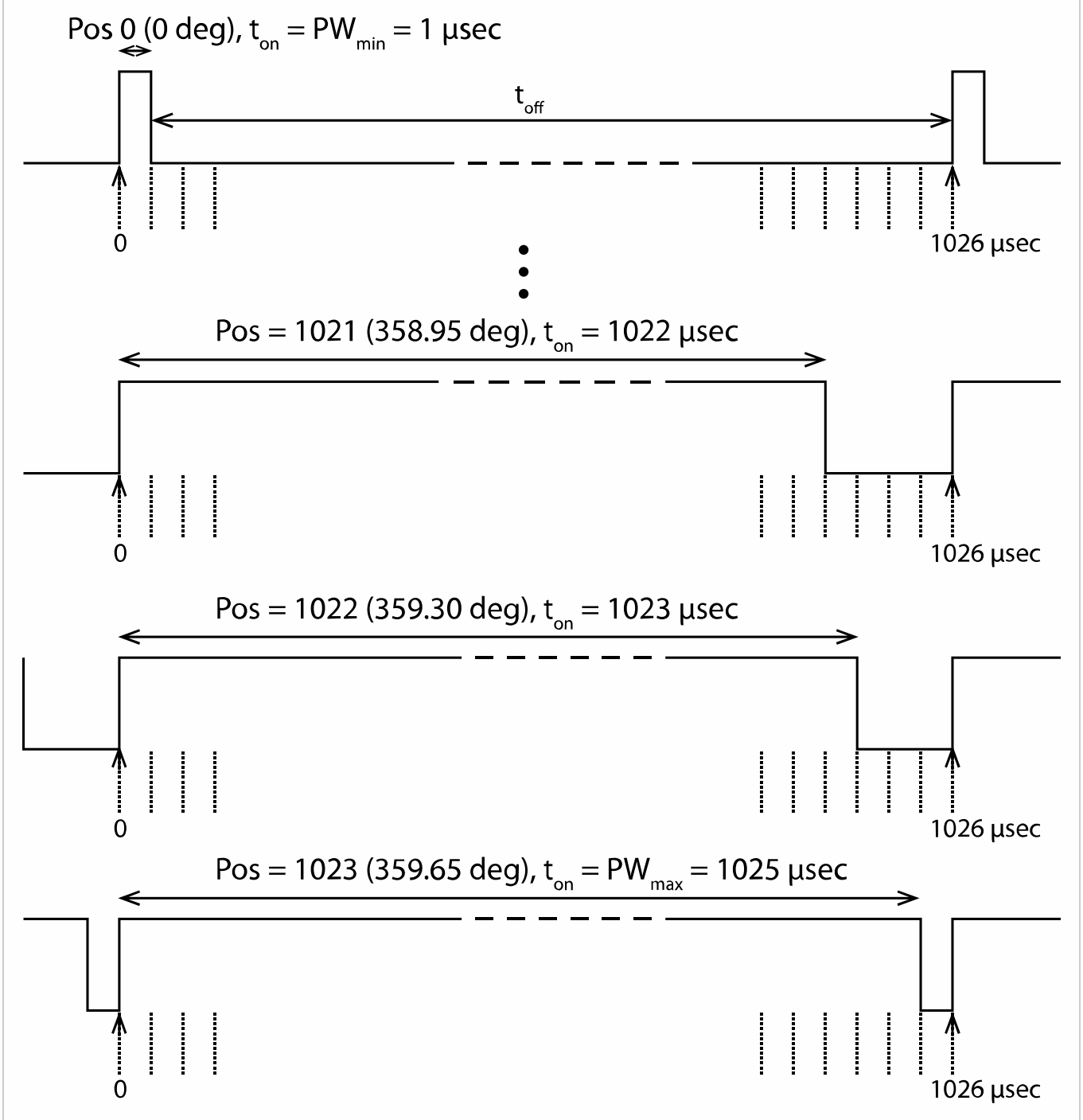

12-bit PWM:

$$x = ((t_{on} * 4098) / (t_{on} + t_{off})) - 1$$

If $x \leq 4094$, then Position = x

If $x = 4096$, then Position = 4095

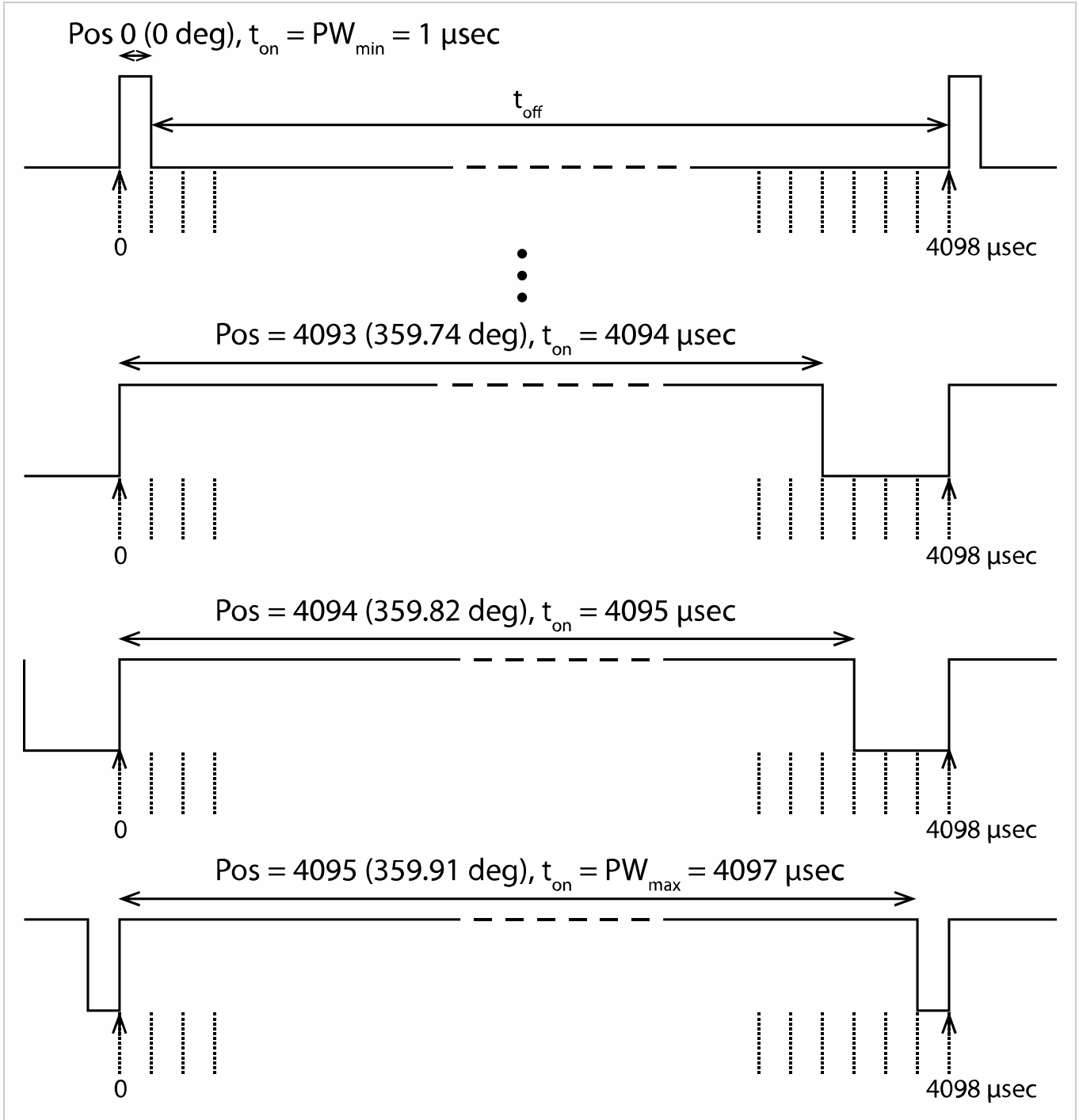



PIN-OUTS

ANALOG OUTPUT (MA3-A):

PIN	NAME	DESCRIPTION
1	5	+5VDC power
2	A	Analog output
3	G	Ground

PWM OUTPUT (MA3-P10, MA3-P12):

PIN	NAME	DESCRIPTION
1	5	+5VDC power
2	A	PWM output
3	G	Ground

CABLES / CONNECTORS

3-PIN MICRO:

PART #	DESCRIPTION
CON-MIC3 (https://www.usdigital.com/products/accessories/connectors/con-mic3/)	Connector
CA-MIC3-W3-NC (https://www.usdigital.com/products/accessories/cables/3-pin/ca-mic3-w3-nc/)	Connector on one end with 3 wires
CA-MIC3-SH-NC (https://www.usdigital.com/products/accessories/cables/3-pin/ca-mic3-sh-nc/)	Connector on one end with shielded cable

- Connector built into encoder: Molex# 53398-0371.
- Mating connector housing: Molex# 51021-0300.
- Mating connector individual crimp-on pins: Molex# 50079-8100.
- To install connector pins, a special crimp tool is needed: Molex# 50079.

Notes

- Cables and connectors are not included and must be ordered separately.
- US Digital® warrants its products against defects in materials and workmanship for two years. See complete warranty (<https://www.usdigital.com/company/warranty>) for details.



Configuration Options

MA3	Output	Shaft Diameter	Torque
	A10 (<i>Analog 10-Bit</i>)	125 (<i>1/8"</i>)	D (<i>Default Torque</i>)
	P10 (<i>PWM 10-Bit</i>)	236 (<i>6mm</i>)	B (<i>Ball Bearing</i>)
	P12 (<i>PWM 12-Bit</i>)	250 (<i>1/4"</i>)	N (<i>Light Static Drag</i>)

PLEASE NOTE: This chart is for informational use only. Certain product configuration combinations are not available. Visit the MA3 product page (<https://www.usdigital.com/products/MA3>) for pricing and additional information.